

Product datasheet

Specifications



motion servo drive - Lexium 23 - single phase 200...255 V - 400 W - I/ O

LXM23DU04M3X

⚠ Discontinued on: 31 Dec 2023

⚠ End-of-service on: 31 Dec 2023

⚠ Discontinued - Service only

Main

Range of product	Lexium 23 Plus
Product or component type	Motion servo drive
Device short name	LXM23

Complementary

Format of the drive	Book
Network number of phases	Single phase 3 phases
[Us] rated supply voltage	220 V single phase (tolerance: - 10...15 %) 220 V 3 phases (tolerance: - 20...15 %)
Supply voltage limits	200...255 V single phase 170...255 V 3 phases
Supply frequency	50/60 Hz - 5...5 %
Network frequency limits	47.5...63 Hz
Continuous output current	2.6 A
Continuous power	400 W at 220 V
Nominal power	0.4 kW at 220 V
Maximum leakage current	3.5 mA
Output voltage	<= power supply voltage
Electrical isolation	Between power and control
Type of cable	Twisted shielded pairs cable (single or double) (temperature: 0...55 °C)
Electrical connection	Terminal, clamping capacity: 1.3 mm ² , AWG 16 (L1-L2) Terminal, clamping capacity: 2.1 mm ² , AWG 14 (R, S, T) Terminal, clamping capacity: 0.82 mm ² , AWG 18 (U, V, W) Terminal, clamping capacity: 2.1 mm ² , AWG 14 (PA/+, PBe)
Tightening torque	PE (ground): 1.4 N.m
Discrete input number	8 programmable discrete input(s)
Discrete input type	Programmable (CN1 terminals)
Discrete input voltage	12...24 V DC for logic
Discrete input logic	Positive or negative (CN1)
Discrete output number	5
Discrete output type	Logic output(s) (CN1)12...24 V DC
Discrete output voltage	12...24 V DC

Discrete output logic	Positive or negative (CN1)
Analogue input number	2
Absolute accuracy error	0.01 %
Analogue input type	V_REF voltage analog input: - 10...10 V, impedance: 10 kOhm T_REF voltage analog input: - 10...10 V, impedance: 10 kOhm
Control signal type	Servo motor encoder feedback
Protection type	Against reverse polarity: inputs signal Against short-circuits: outputs signal Overcurrent: motor Overvoltage: motor Undervoltage: motor Overheating: motor Overload: motor Overspeed: motor Abnormal pulse control command: drive
Communication interface	Modbus, integrated
Connector type	RJ45 (CN3) for Modbus
Method of access	Slave
Physical interface	2-wire RS485 multidrop for Modbus
Transmission rate	Configurable
Status LED	1 LED charge LED
Signalling function	Servo status and fault codes five 7-segment display units
Marking	CE
Type of cooling	Natural convection
Operating position	Vertical
Width	60 mm
Height	162 mm
Depth	146 mm
Net weight	1.7 kg

Environment

EMC filter	Without EMC filter
Electromagnetic compatibility	EMC immunity level 3 conforming to EN/IEC 61000-4-2 EMC immunity level 3 conforming to EN/IEC 61000-4-3 EMC immunity level 3 conforming to EN/IEC 61000-4-5 EMC immunity level 4 conforming to EN/IEC 61000-4-4 EMC immunity with additional EMC filter conforming to EN/IEC 61800-3 environments 1 and 2 Conducted and radiated emissions with additional EMC filter conforming to EN/IEC 61800-3 environments 1 and 2 category C2, C3
Standards	EN/IEC 61800-5-1
Product certifications	cULus 508 C-Tick
IP degree of protection	On upper part: IP20 (without protective cover) On upper part: IP41 (with protective cover)
Vibration resistance	0.075 mm peak to peak (f= 10...57 Hz) conforming to IEC 60068-2-6 1 gn (f= 57...150 Hz) conforming to IEC 60068-2-6
Shock resistance	15 gn for 11 ms conforming to IEC 60068-2-27
Relative humidity	Class 3K3 (5 to 85 %) without condensation or dripping water conforming to IEC 60721-3-3

Ambient air temperature for operation	0...55 °C conforming to UL
Ambient air temperature for storage	-20...65 °C
Operating altitude	<= 1000 m without derating > 1000...2000 m with continuous power derating of 1 % per 100 m

Packing Units

Unit Type of Package 1	PCE
Number of Units in Package 1	1
Package 1 Height	16.3 cm
Package 1 Width	20.0 cm
Package 1 Length	22.9 cm
Package 1 Weight	1.52 kg
Unit Type of Package 2	S06
Number of Units in Package 2	18
Package 2 Height	73.5 cm
Package 2 Width	60.0 cm
Package 2 Length	80.0 cm
Package 2 Weight	40.36 kg

Contractual warranty

Warranty (in months)	18
-----------------------------	----



Environmental Data

Schneider Electric aims to achieve Net Zero status by 2050 through supply chain partnerships, lower impact materials, and circularity via our ongoing “Use Better, Use Longer, Use Again” campaign to extend product lifetimes and recyclability.

[Environmental Data explained >](#)

[How we assess product sustainability >](#)



Environmental footprint

[Environmental Disclosure](#)

[Product Environmental Profile](#)

Use Longer



Lifetime extension

[Repair](#)

[No](#)

Use Again



Repack and remanufacture

[WEEE Label](#)



The product must be disposed on European Union markets following specific waste collection and never end up in rubbish bins

Dimensions Drawings

Dimensions

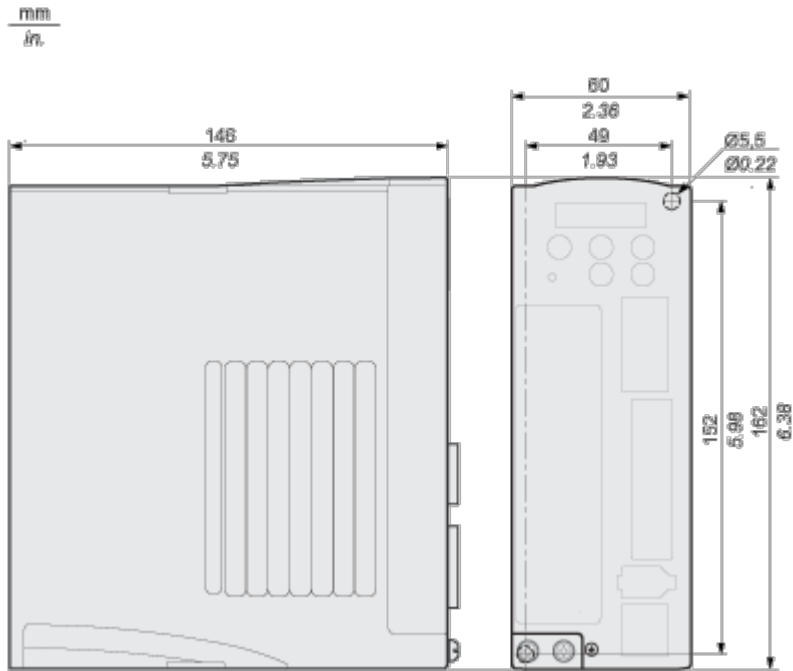

Mounting and Clearance

Mounting Recommendations

Mount the device in a vertical position ($\pm 10^\circ$). This is required for cooling the device.

Clearance

Many Devices in a cabinet

$\frac{\text{mm}}{\text{in.}}$

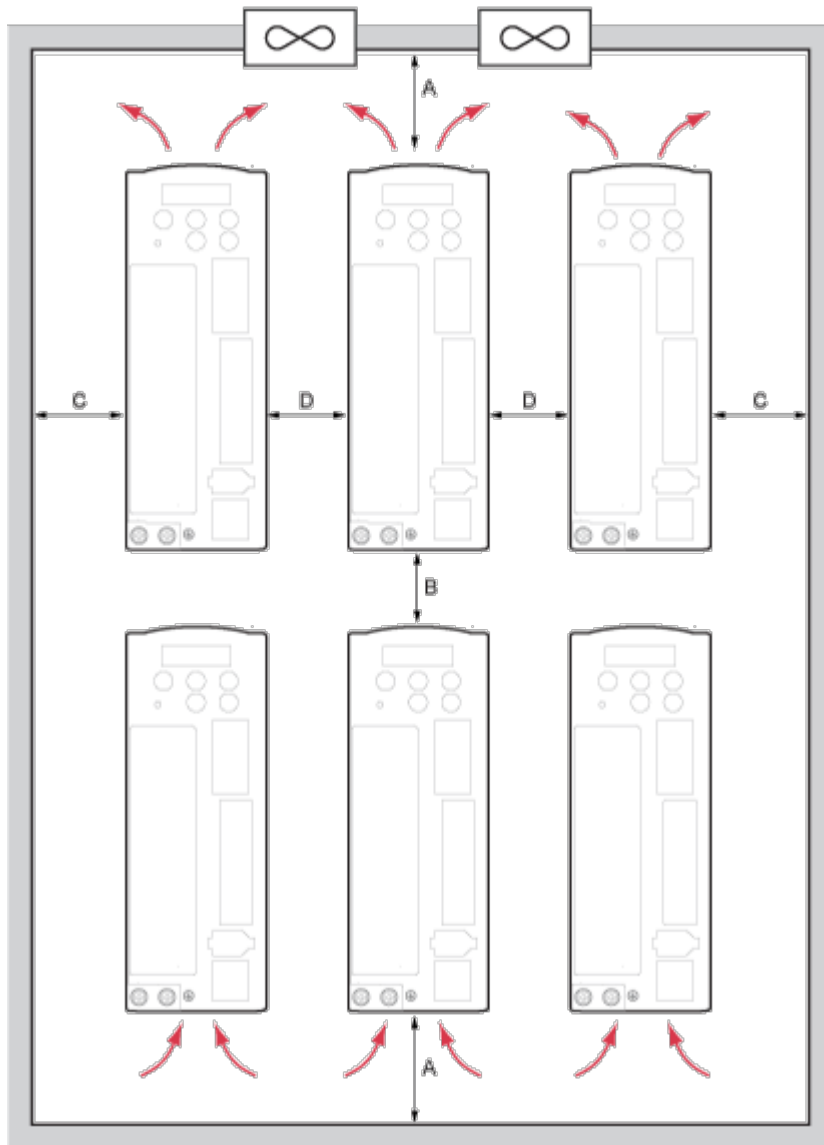

A ≥ 100 mm (≥ 4 in.)	Free space above/below devices
B ≥ 80 mm (≥ 3.2 in.)	Free space between devices
C ≥ 40 mm (≥ 1.6 in.)	Free space between devices and cabinet
D ≥ 10 mm (≥ 0.4 in.)	Free space between devices

One Device in a cabinet

mm
in.

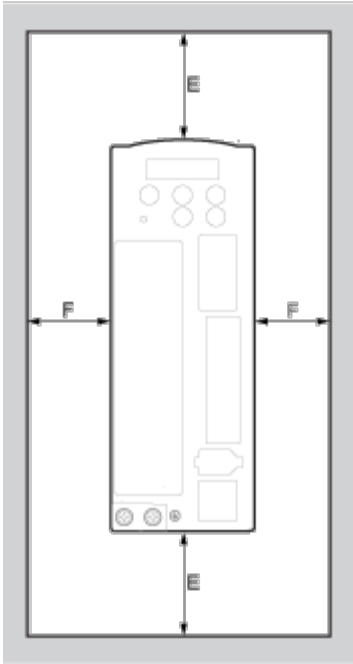

E ≥ 50 mm (≥ 2 in.)	Free space above/below the device
F ≥ 20 mm (≥ 0.8 in.)	Free space between device and cabinet

Connections and Schema

Position Control Mode Wiring Diagram (Pulse Control)

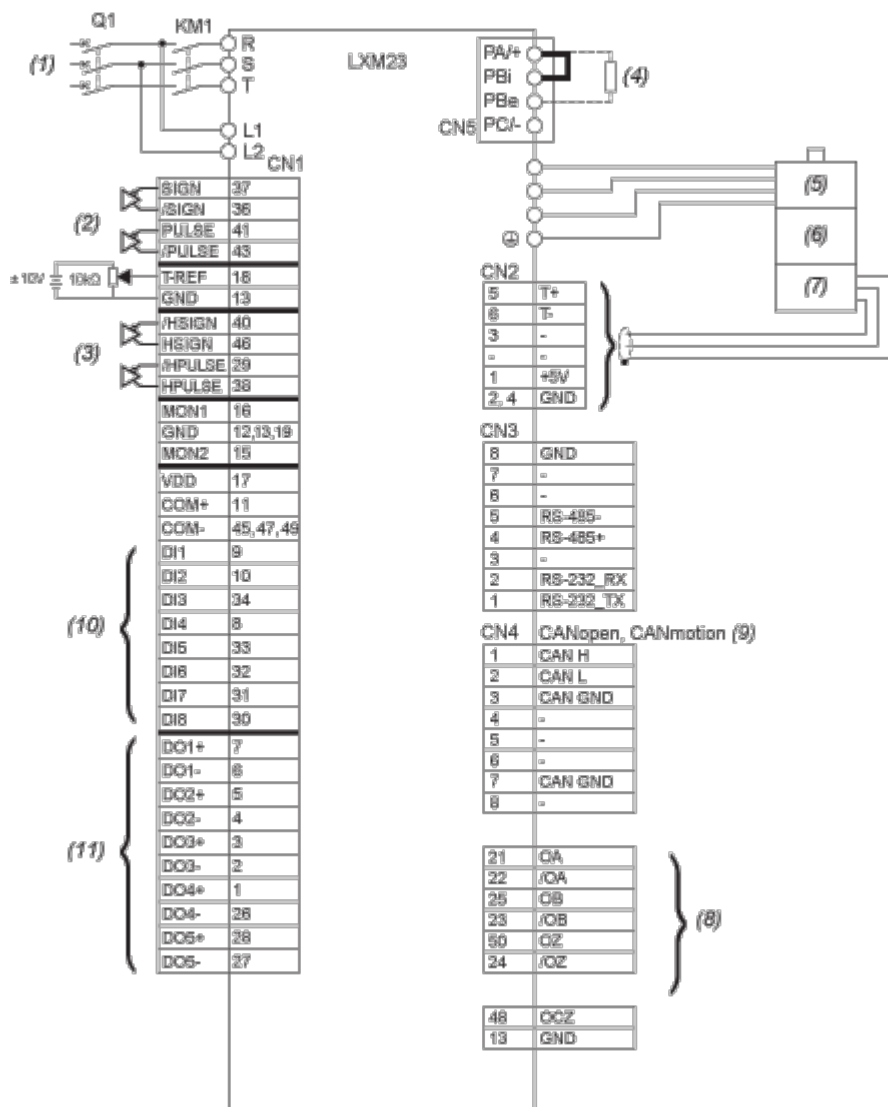

KM1 Line Contactor

Q1 Circuit breaker

(1) AC 220 / 230 V Single Phase or Three Phase 50 / 60 Hz

(2) Pulse Input (Line Driver)

(3) High-Speed Pulse Input (Line Receiver)

(4) External Braking Resistor

(5) Power Supply

(6) Holding Brake

(7) Encoder

(8) Encoder Pulse Output

(9) Only LXM23A models

(10) Digital inputs

(11) Digital outputs

Position Control Mode Wiring Diagram (Build-In Motion Sequence)

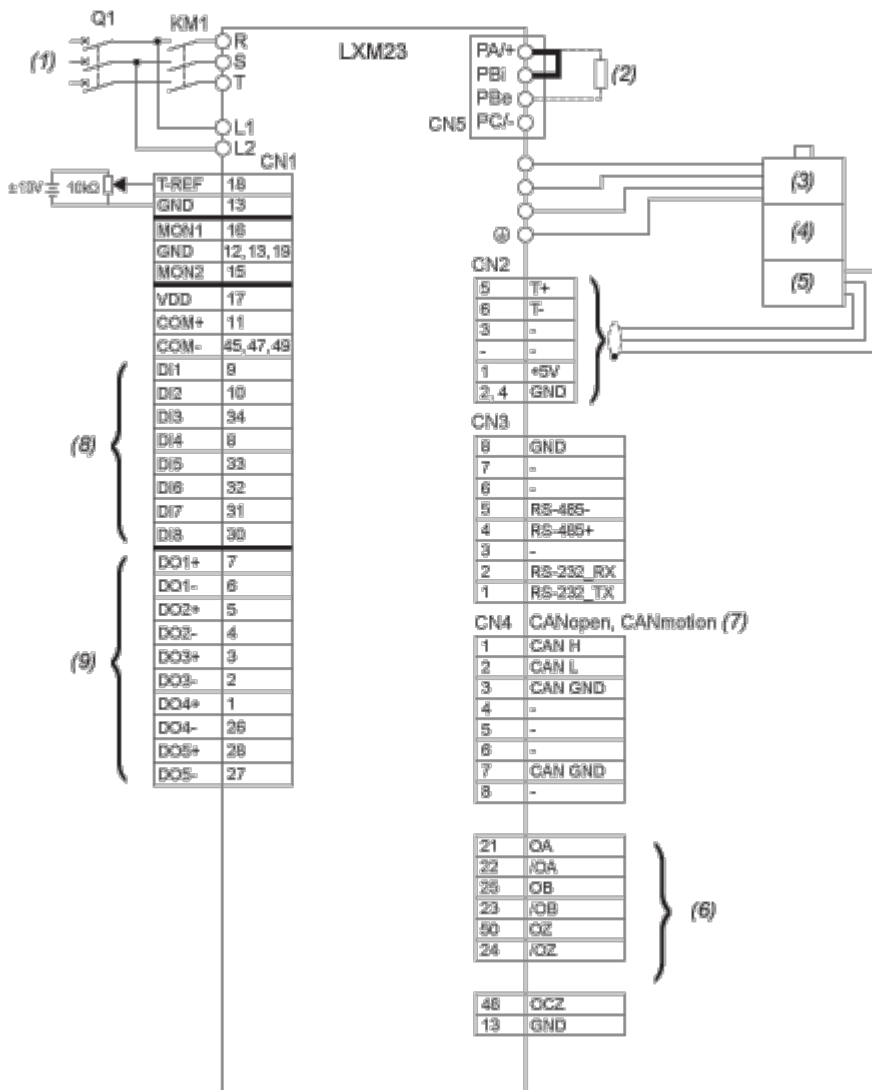

KM1 Line Contactor

Q1 Circuit breaker

(1) AC 220 / 230 V Single Phase or Three Phase 50 / 60 Hz

(2) External Braking Resistor

(3) Power Supply

(4) Holding Brake

(5) Encoder

(6) Encoder Pulse Output

(7) Only LXM23A models

(8) Digital inputs

(9) Digital outputs

Speed Control Mode Wiring Diagram

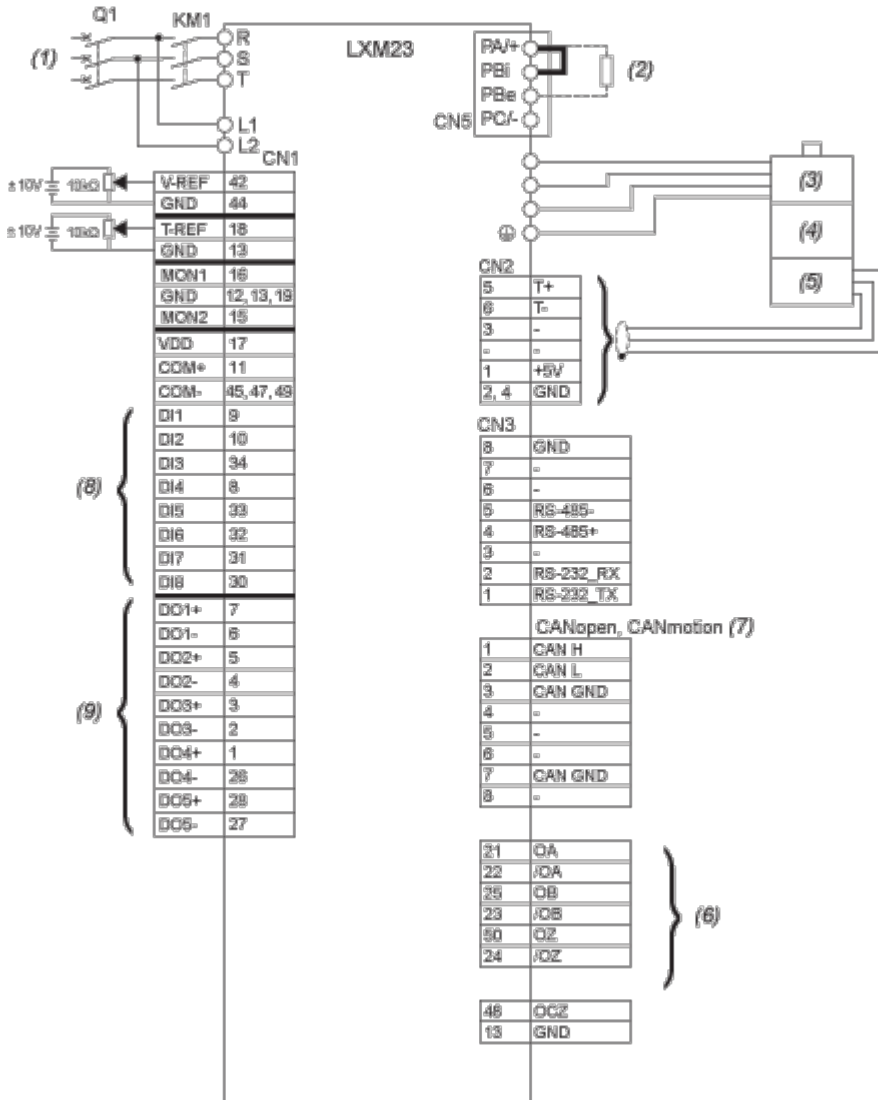

KM1 Line Contactor

Q1 Circuit breaker

(1) AC 220 / 230 V Single Phase or Three Phase 50 / 60 Hz

(2) External Braking Resistor

(3) Power Supply

(4) Holding Brake

(5) Encoder

(6) Encoder Pulse Output

(7) Only LXM23A models

(8) Digital inputs

(9) Digital outputs

Torque Control Mode Wiring Diagram

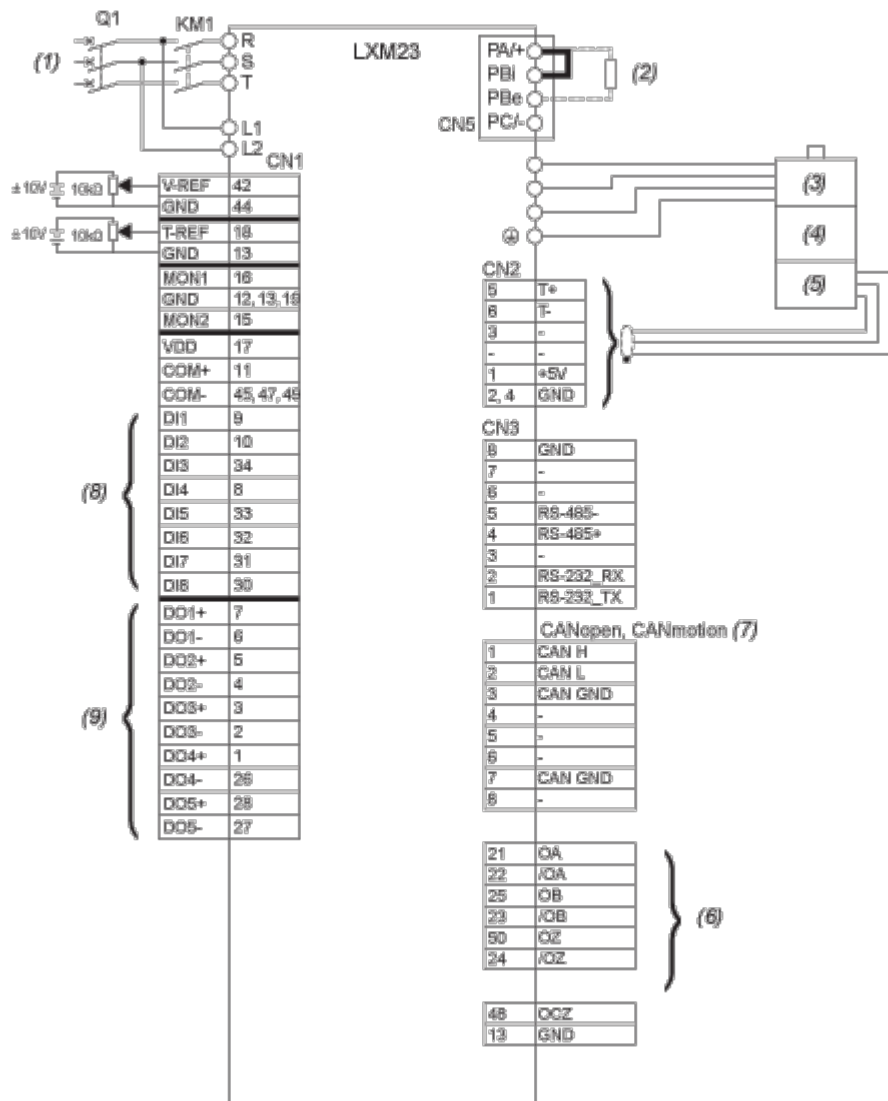

KM1 Line Contactor

Q1 Circuit breaker

(1) AC 220 / 230 V Single Phase or Three Phase 50 / 60 Hz

(2) External Braking Resistor

(3) Power Supply

(4) Holding Brake

(5) Encoder

(6) Encoder Pulse Output

(7) Only LXM23A models

(8) Digital inputs

(9) Digital outputs