

Product data sheet

Specifications



RM4, three-phase network control relay RM4-T - range 200..500V

RM4TG20

⚠ Discontinued on: Jan 23, 2021

⚠ Discontinued

Main

Range of Product	Harmony Relay
Relay Type	Control relay
Product or Component Type	Industrial measurement and control relays
Relay name	RM4-T
Relay monitored parameters	Phase failure detection Phase sequence
Time delay type	Without
Output contacts	2 C/O
Contacts type and composition	2 C/O
Poles description	3P
Product Specific Application	For 3-phase supply

Complementary

[Ie] rated operational current	2 A 158 °F (70 °C) 24 V DC-13 IEC 60947-5-1/1991 2 A 158 °F (70 °C) 24 V DC-13 VDE 0660 3 A 158 °F (70 °C) 115 V AC-15 IEC 60947-5-1/1991 3 A 158 °F (70 °C) 115 V AC-15 VDE 0660 3 A 158 °F (70 °C) 24 V AC-15 IEC 60947-5-1/1991 3 A 158 °F (70 °C) 24 V AC-15 VDE 0660 3 A 158 °F (70 °C) 250 V AC-15 IEC 60947-5-1/1991 3 A 158 °F (70 °C) 250 V AC-15 VDE 0660 0.1 A 158 °F (70 °C) 250 V DC-13 IEC 60947-5-1/1991 0.1 A 158 °F (70 °C) 250 V DC-13 VDE 0660 0.3 A 158 °F (70 °C) 115 V DC-13 IEC 60947-5-1/1991 0.3 A 158 °F (70 °C) 115 V DC-13 VDE 0660
Maximum switching voltage	440 V AC
Setting accuracy of time delay	10 P
delay at power up	650 ms
Maximum measuring cycle	80 ms
[Ui] rated insulation voltage	500 V IEC
Supply frequency	50/60 Hz +/- 5 %
Operating position	Any position without derating
Connections - terminals	Screw terminals, 2 x 1.5 mm ² flexible with cable end Screw terminals, 2 x 2.5 mm ² flexible without cable end
Tightening torque	5.3...9.7 lbf.in (0.6...1.1 N.m)
Mechanical durability	30000000 cycles
[Ith] conventional free air thermal current	8 A

Price is "List Price" and may be subject to a trade discount – check with your local distributor or retailer for actual price.

Switching capacity in mA	10 mA 12 V
Switching voltage	250 V AC
Contacts material	90/10 silver nickel contacts
Number of cables	2
Height	3.07 in (78 mm)
Width	0.9 in (22.5 mm)
Depth	3.1 in (80 mm)
Terminals description ISO n°1	(L1-L2-L3)CO (15-16-18)OC (25-26-28)OC ALT
Output relay state	Tripped, fault present
9 mm pitches	2.5
Net Weight	0.24 lb(US) (0.11 kg)
Terminals description ISO n°2	(11-12-14)OC ALT (L1-L2-L3)CO (21-22-24)OC

Environment

Electromagnetic compatibility	Electrostatic discharge - test level: 6 kV level 3 (contact discharge) conforming to IEC 61000-4-2 Electrostatic discharge - test level: 8 kV level 3 (air discharge) conforming to IEC 61000-4-2 Resistance to electrostatic discharge - test level: 6 kV (contact) conforming to IEC 61000-4-2 level 3 Resistance to electrostatic discharge - test level: 8 kV (air) conforming to IEC 61000-4-2 level 3
Standards	EN/IEC 60255-6
Product Certifications	GL UL CSA
Marking	CE
Directives	73/23/EEC - low voltage directive 89/336/EEC - electromagnetic compatibility
Ambient Air Temperature for Storage	-40...185 °F (-40...85 °C)
Ambient air temperature for operation	-4...149 °F (-20...65 °C)
Relative humidity	15...85 % 3K3 IEC 60721-3-3
Vibration resistance	0.35 ms (f= 10...55 Hz) conforming to IEC 60068-2-6
Shock resistance	15 gn 11 ms IEC 60068-2-27
IP degree of protection	IP20 IEC 60529 terminals) IP50 IEC 60529 casing)
Pollution degree	3 IEC 60664-1
Overvoltage category	III conforming to IEC 60664-1
Dielectric test voltage	2.5 kV
Non-dissipating shock wave	4.8 kV
Resistance to electrostatic discharge	6 kV contact IEC 61000-4-2 level 3 8 kV air IEC 61000-4-2 level 3
Resistance to electromagnetic fields	9.1 V/m (10 V/m) IEC 61000-4-3 level 3

Resistance to fast transients	2 kV IEC 61000-4-4 level 3
--------------------------------------	----------------------------

Disturbance radiated/conducted	CISPR 11 group 1 - class A CISPR 22 - class A
---------------------------------------	--

Ordering and shipping details

Category	22376-RELAYS-MEASUREMENT(RM4)
-----------------	-------------------------------

Discount Schedule	CP2
--------------------------	-----

GTIN	00785901481638
-------------	----------------

Returnability	No
----------------------	----

Country of origin	ID
--------------------------	----

Packing Units

Unit Type of Package 1	PCE
-------------------------------	-----

Nbr. of units in pkg.	1
------------------------------	---

Contractual warranty

Warranty (in months)	18
-----------------------------	----



Environmental Data

Schneider Electric aims to achieve Net Zero status by 2050 through supply chain partnerships, lower impact materials, and circularity via our ongoing “Use Better, Use Longer, Use Again” campaign to extend product lifetimes and recyclability.

[Environmental Data explained >](#)

[How we assess product sustainability >](#)

Use Longer



Lifetime extension

Repair

No

Dimensions Drawings

3-phase Supply Control Relays

Dimensions

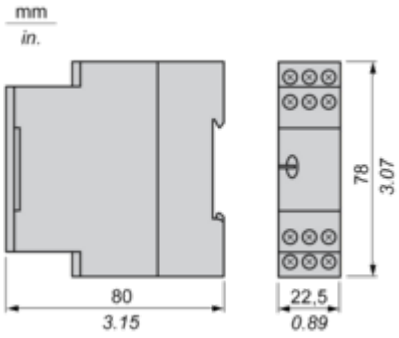

Mounting and Clearance

3-phase Supply Control Relays

Rail mounting

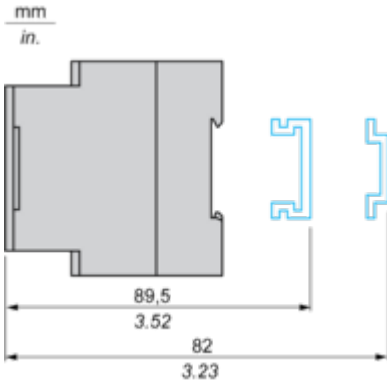

Screw fixing

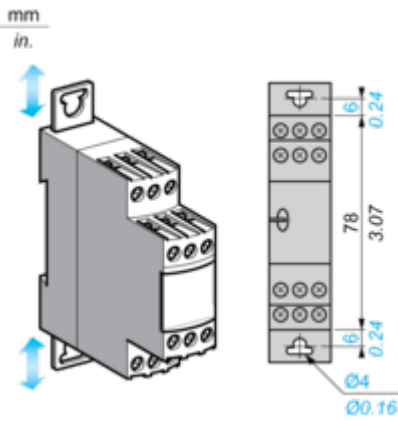

Connections and Schema

3-Phase Supply Control Relays

Wiring Diagram

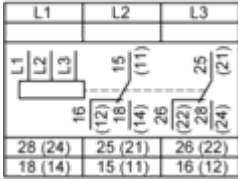

L1, L2, L3 Supply to be monitored

15(11)-18(14), 15(11)-16(12) 1st C/O contact of the output relay

25(21)-28(24), 25(21)-26(22) 2nd C/O contact of the output relay

Application Scheme

Example

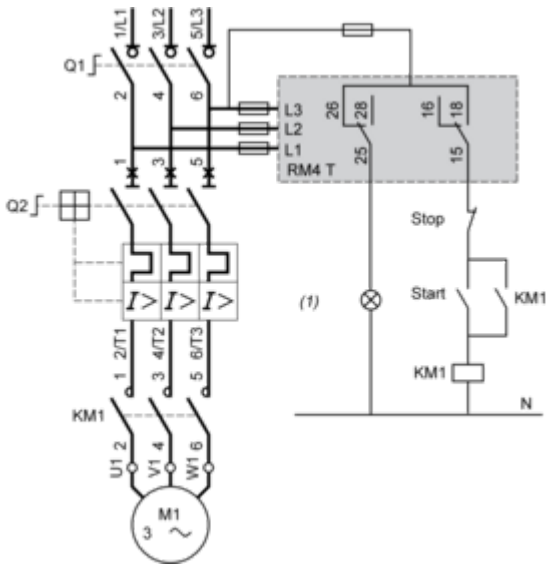

(1) Fault

Performance Curves

Electrical Durability and Load Limit Curves

AC Load

Curve 1: Electrical durability of contacts on resistive load in millions of operating cycles

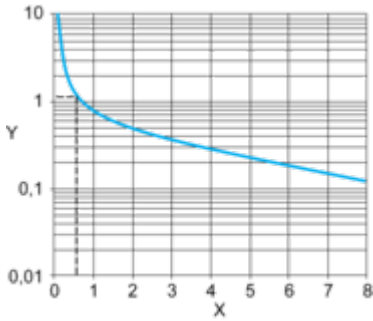

X Current broken in A

Y Millions of operating cycles

Curve 2: Reduction factor k for inductive loads (applies to values taken from durability Curve 1)

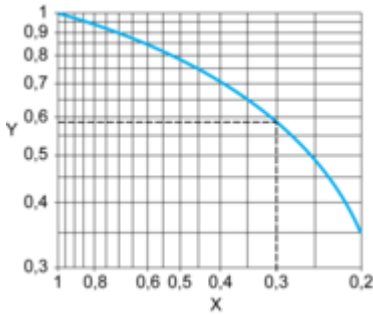

X Power factor on breaking (cos φ)

Y Reduction factor K

DC Load

Load limit curve

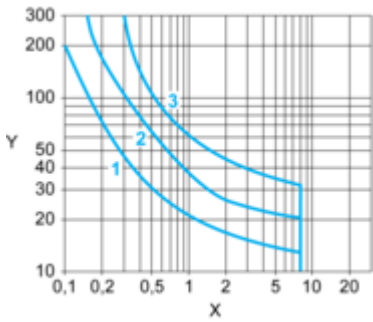

X Current in A

Y Voltage in V

1 L/R = 20 ms

2 L/R with load protection diode

3 Resistive load

