

Product data sheet

Specifications

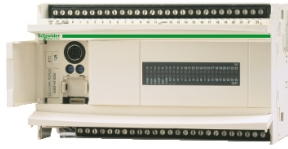

Compact base controller, Twido, 100 to 240VAC supply, compact, 14 inputs with 24VDC, 10 output relays

TWDLCAA40DRF

⚠ Discontinued on: Jul 31, 2024

⚠ Discontinued

Main

| | |
|--|---|
| Range of Product | Twido |
| Product or Component Type | Compact base controller |
| Discrete I/O number | 40 |
| Discrete input number | 24 |
| Discrete input voltage | 24 V |
| Discrete input voltage type | DC |
| Discrete output number | 14 relay 2 transistor |
| [Us] rated supply voltage | 100...240 V AC |
| Maximum Number of I/O Expansion Module | 7 |
| Use of slot | Memory cartridge |
| Data backed up | Internal RAM external battery TSXPLP01, 3 years |
| Integrated connection type | Power supply Non isolated serial link mini DIN, Modbus/character mode master/slave RTU/ASCII RS485) half duplex, 38.4 kbit/s Serial link interface adaptor RS232C/RS485) |
| Complementary function | Event processing PID |
| Range Compatibility | Twido |

Complementary

| | |
|---|---|
| Discrete input logic | Sink or source |
| Input voltage limits | 20.4...26.4 V |
| Discrete input current | 11 mA I0.0 to I0.1 11 mA I0.6 to I0.7 7 mA I0.2 to I0.5 7 mA I0.8 to I0.23 |
| Input impedance | 2100 Ohm I0.0 to I0.1 2100 Ohm I0.6 to I0.7 3400 Ohm I0.2 to I0.5 3400 Ohm I0.8 to I0.23 |
| Filter time | 150 μ s + programmed filter time for I0.6 to I0.23 at state 0 35 μ s + programmed filter time for I0.0 to I0.5 at state 1 40 μ s + programmed filter time for I0.0 to I0.5 at state 0 40 μ s + programmed filter time for I0.6 to I0.23 at state 1 |
| Insulation between channel and internal logic | 1500 Vrms for 1 minute |
| Insulation resistance between channel | None |

Price is "List Price" and may be subject to a trade discount – check with your local distributor or retailer for actual price.

| | |
|--------------------------------------|--|
| Minimum load | 0.1 mA |
| Contact resistance | 30000 µOhm |
| Load current | 2 A 240 V AC inductive 30 cyc/mn relay output 2 A 240 V AC resistive 30 cyc/mn relay output 2 A 30 V DC inductive 30 cyc/mn relay output 2 A 30 V DC resistive 30 cyc/mn relay output |
| Mechanical durability | 20000000 cycles relay output |
| Electrical durability | 100000 cycles relay output |
| Current consumption | 128 mA 24 V DC at state 1 128 mA 24 V DC state 1 + input ON 140 mA 5 V DC state 1 + input ON 5 mA 24 V DC at state 0 70 mA 5 V DC at state 0 90 mA 5 V DC at state 1 |
| I/O connection | Non-removable screw terminal block |
| Maximum input/output number | 152 removable screw terminal block with I/O expansion module 208 spring terminal block with I/O expansion module 264 HE-10 connector with I/O expansion module |
| Network Frequency | 50/60 Hz |
| Supply voltage limits | 85...264 V |
| Network frequency limits | 47...63 Hz |
| Power supply output current | 0.4 A 24 V DC sensors |
| Input current | 790 mA |
| Inrush current | 35 A |
| Protection type | Power protection internal fuse |
| Power consumption in VA | 65 VA 100 V 77 VA 264 V |
| Insulation resistance | > 10 MOhm at 500 V, between I/O and earth terminals > 10 MOhm at 500 V, between supply and earth terminals |
| Program memory | 3000 instructions |
| Exact time for 1 Kinstruction | 1 ms |
| System overhead | 0.5 ms |
| Memory description | Internal RAM, 128 counters, no floating, no trigonometrical Internal RAM, 128 timers, no floating, no trigonometrical Internal RAM, 256 internal bits, no floating, no trigonometrical Internal RAM, 3000 internal words, no floating, no trigonometrical Internal RAM, double words, no floating, no trigonometrical Internal RAM, floating, trigonometrical |
| Free slots | 1 |
| Realtime clock | With <= 30 s/month 30 days |
| Positioning functions | PWM/PLS 2 7 kHz |
| Counting input number | 2 20000 Hz 32 bits 4 5000 Hz 16 bits |
| Analogue adjustment points | 1 point adjustable from 0 to 511 points 1 point adjustable from 0...1023 |
| Status LED | 1 LED (Green) PWR 1 LED (Green) RUN 1 LED per channel (Green) I/O status 1 LED (Red) module error (ERR) 1 LED user pilot light (STAT) |
| Depth | 2.8 in (70 mm) |
| Height | 3.7 in (95 mm) |

| | |
|------------|-------------------------|
| Width | 3.5 in (90 mm) |
| Net Weight | 1.157 lb(US) (0.525 kg) |

Environment

| | |
|---------------------------------------|---|
| Immunity to microbreaks | 10 ms |
| Dielectric strength | 1500 V for 1 minute, between I/O and earth terminals 1500 V for 1 minute, between supply and earth terminals |
| Product Certifications | UL CSA |
| Marking | CE |
| Ambient Air Temperature for Operation | 32...131 °F (0...55 °C) |
| Ambient Air Temperature for Storage | -13...158 °F (-25...70 °C) |
| Relative humidity | 30...95 % without condensation |
| IP Degree of Protection | IP20 |
| Operating altitude | 0...6561.68 ft (0...2000 m) |
| Storage altitude | 0...9842.5 ft (0...3000 m) |
| Vibration resistance | 0.075 mm 10...57 Hz 35 mm symmetrical DIN rail 1 gn 57...150 Hz 35 mm symmetrical DIN rail 1.6 mm 2...25 Hz plate or panel with fixing kit 4 gn 25...100 Hz plate or panel with fixing kit |
| Shock resistance | 15 gn 11 ms |

Ordering and shipping details

| | |
|-------------------|------------------------|
| Category | 22531-PLCS, TWIDO, TWD |
| Discount Schedule | PC12 |
| GTIN | 3595863816013 |
| Returnability | No |
| Country of origin | ID |

Packing Units

| | |
|------------------------------|--------------------------|
| Unit Type of Package 1 | PCE |
| Nbr. of units in pkg. | 1 |
| Package 1 Height | 4.1 in (10.5 cm) |
| Package 1 Width | 4.7 in (12 cm) |
| Package 1 Length | 7.3 in (18.5 cm) |
| Package weight(Lbs) | 24.2 oz (685 g) |
| Unit Type of Package 2 | S03 |
| Number of Units in Package 2 | 8 |
| Package 2 Height | 11.8 in (30 cm) |
| Package 2 Width | 11.8 in (30 cm) |
| Package 2 Length | 15.7 in (40 cm) |
| Package 2 Weight | 13.170 lb(US) (5.974 kg) |

Contractual warranty



Environmental Data

Schneider Electric aims to achieve Net Zero status by 2050 through supply chain partnerships, lower impact materials, and circularity via our ongoing “Use Better, Use Longer, Use Again” campaign to extend product lifetimes and recyclability.

[Environmental Data explained >](#)

[How we assess product sustainability >](#)

Use Longer



Lifetime extension

Repair

No

Dimensions Drawings

Dimensions

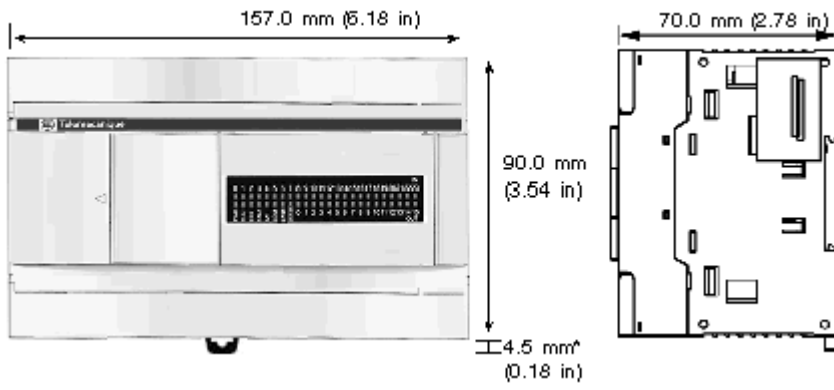

* 8.5 mm (0.33 in) when the clamp is pulled out.

Mounting and Clearance

Minimum Clearances for a Compact Base and Expansion I/O Modules

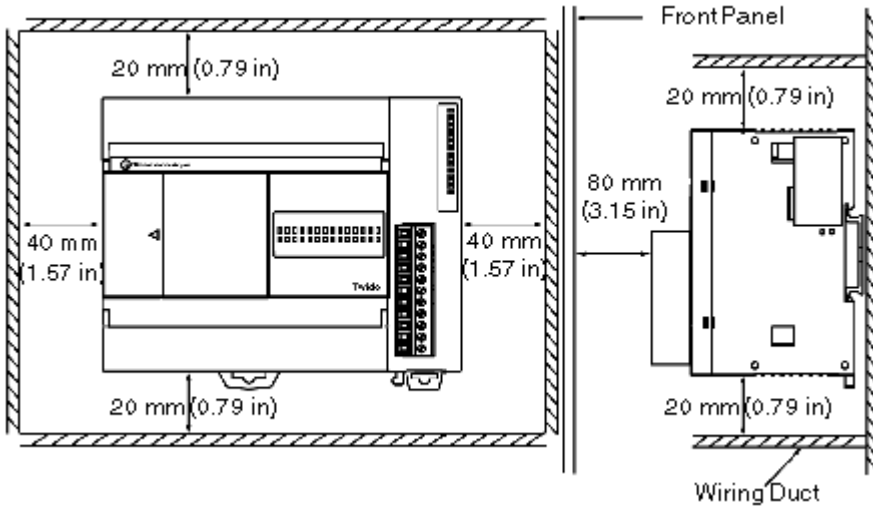

Mounting Hole Layout

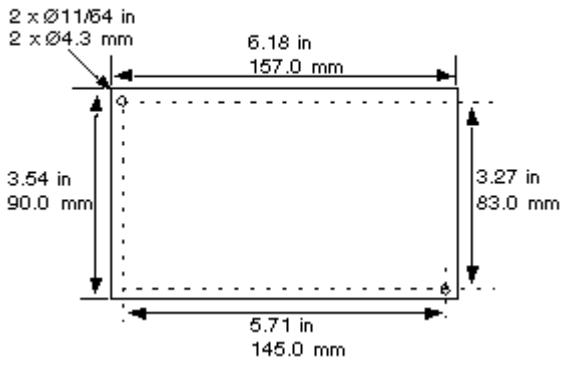

Connections and Schema

AC Power Supply Wiring Diagram

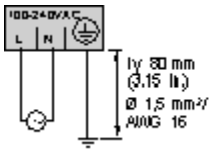

DC Source Inputs Wiring Diagrams

External Power

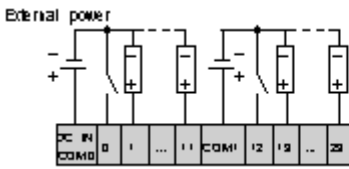

Internal Power

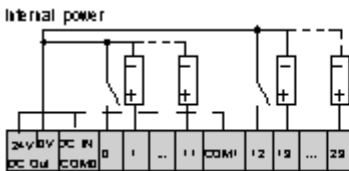

Max current: 400mA.

DC Sink Inputs Wiring Diagrams

External Power

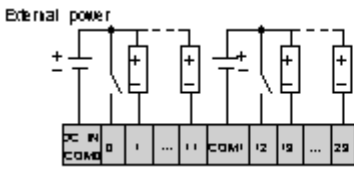

Internal Power

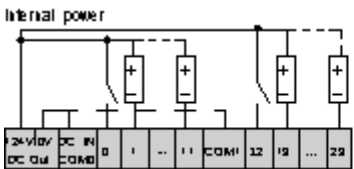

Max current: 400mA.

Relay and Transistor Outputs Wiring Diagram

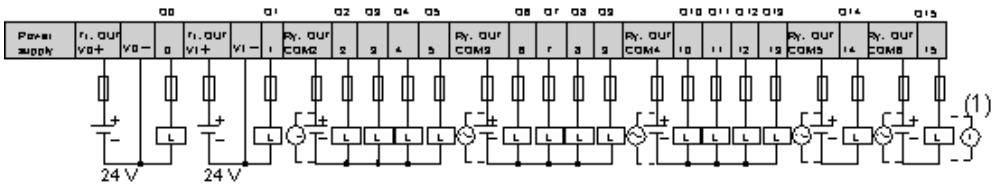

Performance Curves

Performance Curves

I/O Usage Limits

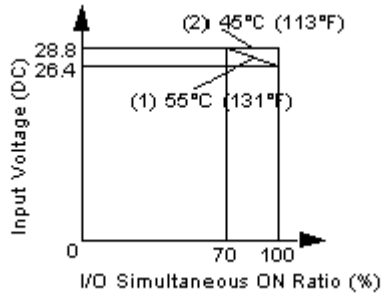

- (1) Limit for TWDLCA•AA16DRF, TWDLCA•A24DRF, TWDLCA•40DRF and TWDLCA•40DRF
- (2) All compact bases